

# FRAME ASSEMBLY DETAIL

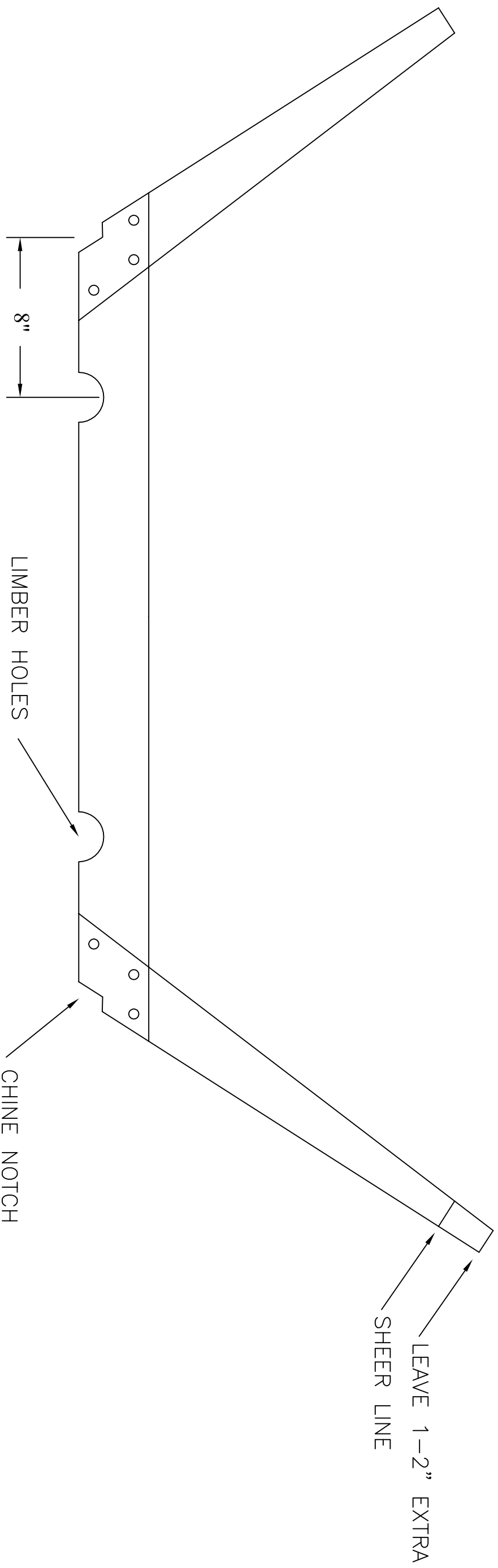

CHINE PROFILE

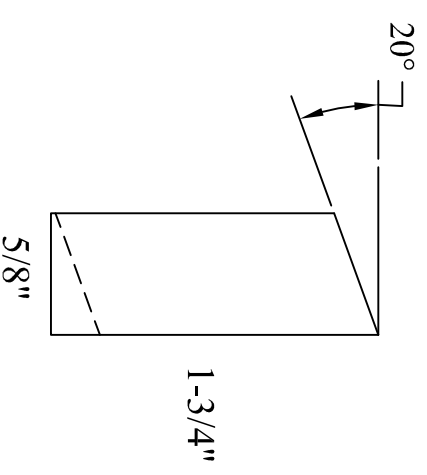

- NOTES:
1. REFER TO INSTRUCTION ON CUTTING FRAMES
  2. CUT CHINE NOTCHES AFTER ASSEMBLY
  3. USE #8X 1" WOOD SCREWS
  4. TAPER SIDE FRAME MEMBERS TO 1-1/4" AT THE SHEER LINE
  5. LIMBER HOLES ALLOW WATER TO DRAIN BETWEEN FRAMES. USE 1-1/4" HOLE SAW
  6. USE 1X4" STOCK FOR ALL FRAME PARTS. CAN PLANE TO 5/8" FOR LIGHTER WEIGHT

\*PLANE CHINE BOTTOM AFTER INSTALLATION

# TRANSOM ASSEMBLY DETAIL

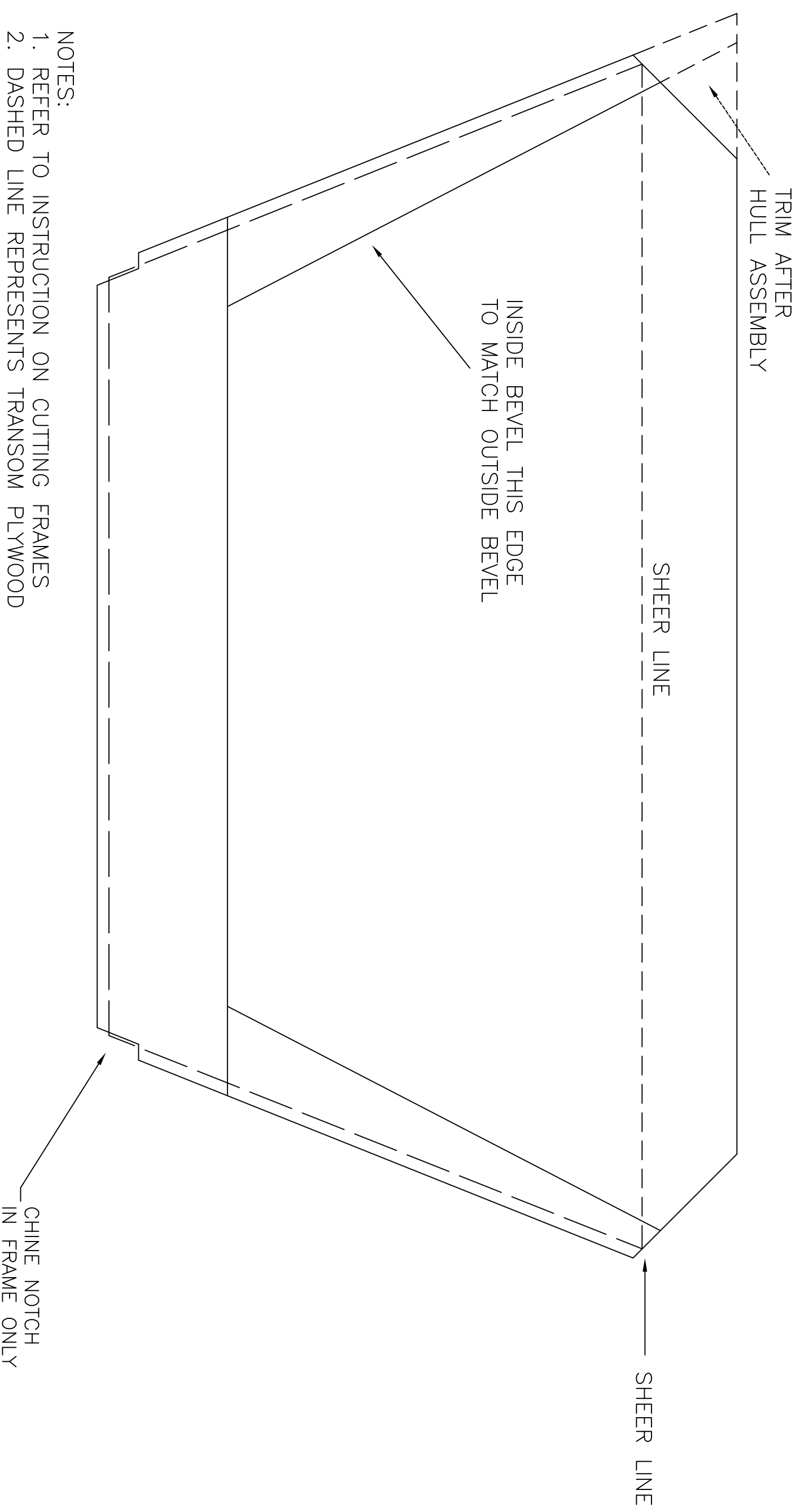

## NOTES:

1. REFER TO INSTRUCTION ON CUTTING FRAMES
2. DASHED LINE REPRESENTS TRANSOM PLYWOOD
3. CHINE NOTCHES ARE CUT BEFORE FRAME ASSEMBLY FOR TRANSOMS
4. CHINE NOTCHES ARE NOT CUT IN PLYWOOD, ONLY FRAMING MEMBERS
5. ASSEMBLE USING EPOXY AND #14 X 1-1/4" RING NAILS
6. BEVEL INSIDE OF SIDE FRAME MEMBERS EQUAL TO OUTSIDE BEVEL
7. TAPER SIDE FRAME MEMBERS TO 1-1/4" AT THE SHEER LINE
8. USE 1X4 STOCK FOR FRAME MEMBERS

# TRANSOM AND SIDE PANEL LAYOUT

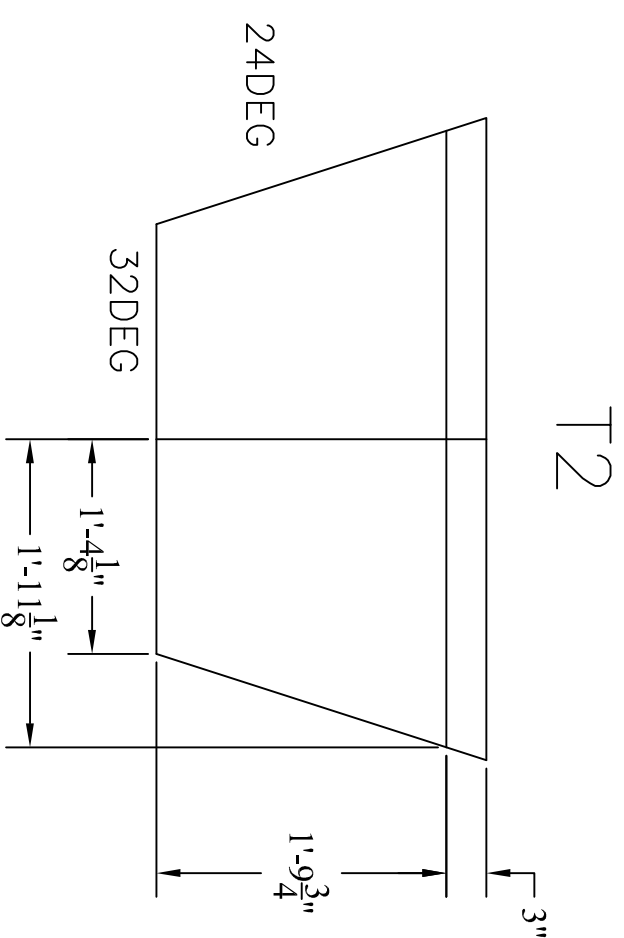
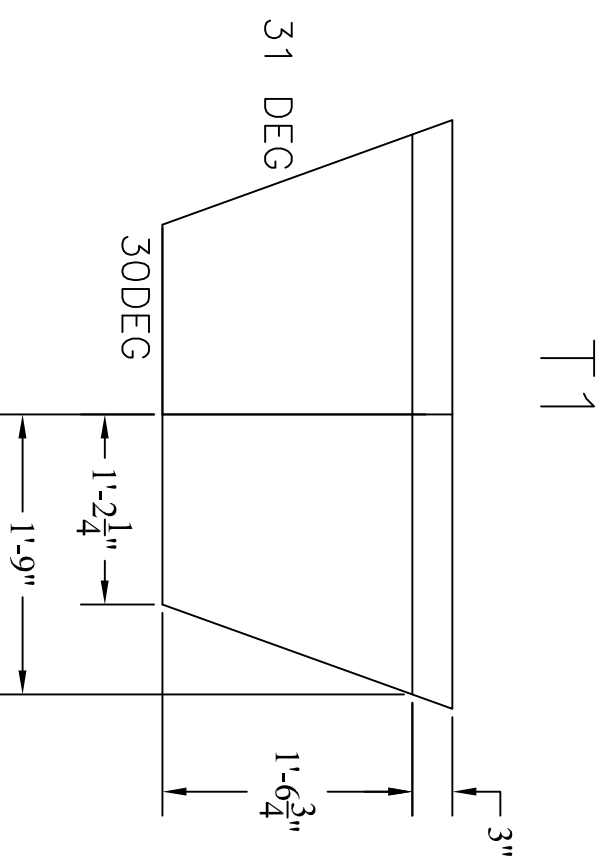
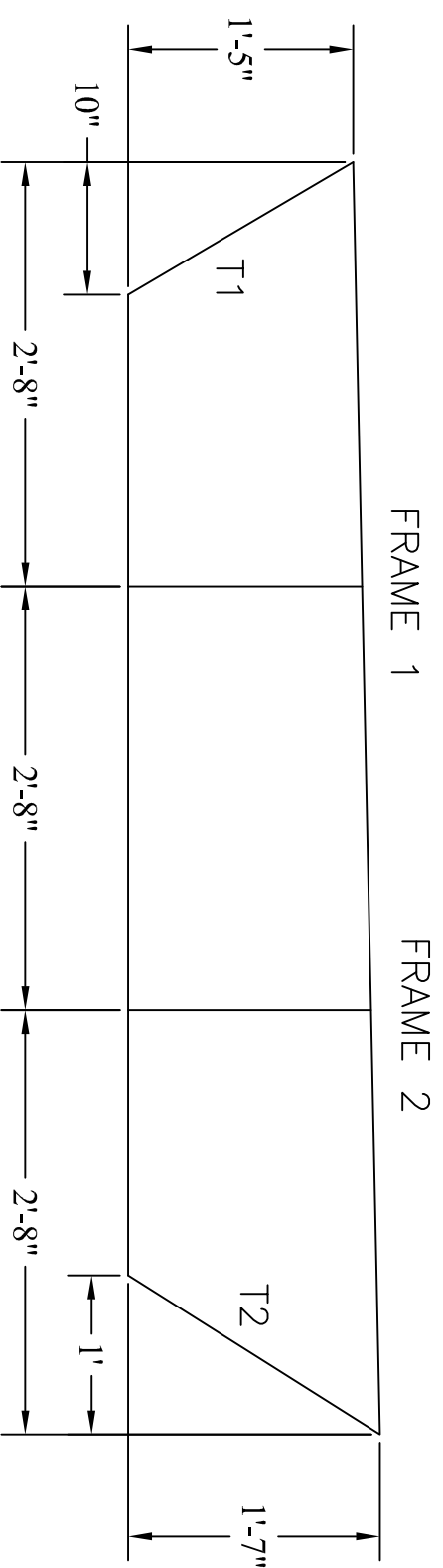

- NOTES:
1. USE 3/8" MARINE PLYWOOD FOR TRANSOMS
  2. LINES SHOW THE CENTERLINE OF TRANSOMS.
  3. SIDE PANEL IS 1/4" (6MM) MARINE PLYWOOD.

PAY CAREFUL ATTENTION TO ACCOUNT FOR SIDE AND BOTTOM BEVELS

# FRAME TABLE OF OFFSETS AND BEVELS

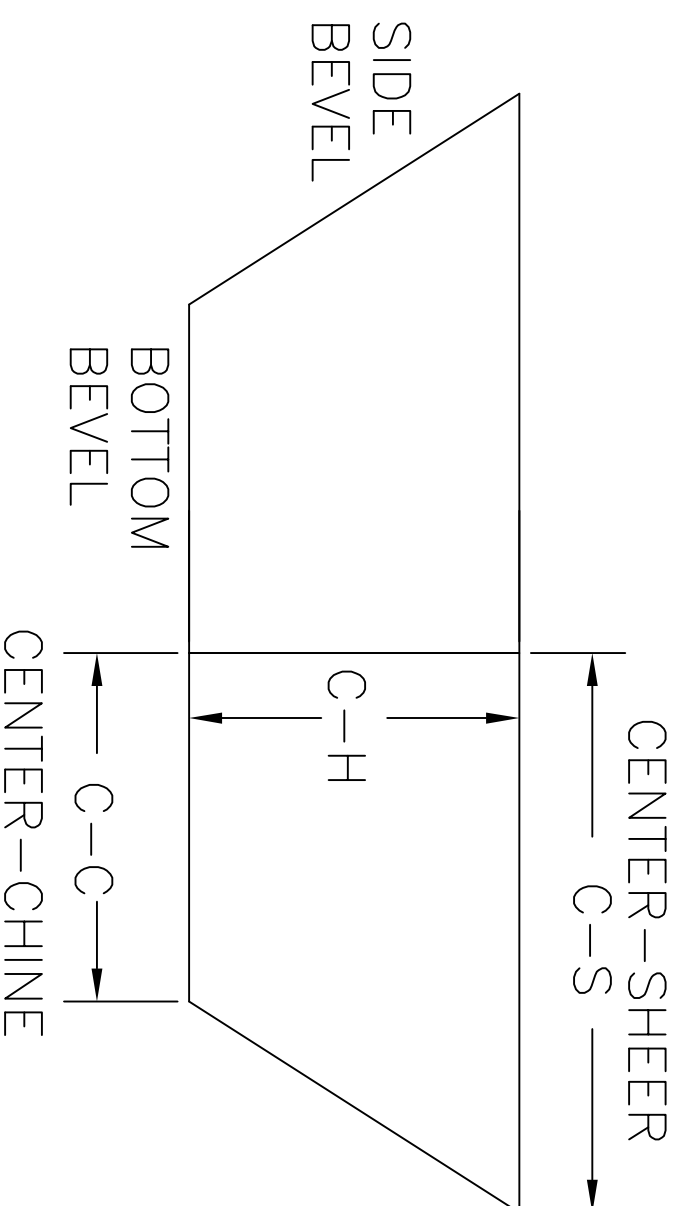

| FRAME NUMBER | C-H   | C-S   | C-C   | BOTTOM BEVEL | BOTTOM BEVEL DIRECTION | SIDE BEVEL | SIDE BEVEL DIRECTION |
|--------------|-------|-------|-------|--------------|------------------------|------------|----------------------|
| 1            | 1-3-4 | 2-1-6 | 1-6-0 | 5 DEG        | T1                     | 8 DEG      | T1                   |
| 2            | 1-4-0 | 2-2-4 | 1-6-5 | 5 DEG        | T2                     | 4 DEG      | T2                   |

## NOTES:

1. ALL MEASUREMENTS IN FEET-INCHES-EIGHTH INCHES
2. REFER TO INSTRUCTION ON CUTTING FRAMES
3. REFER TO SIDE VIEW AND BREADTH VIEW FOR BEVEL DIRECTION
4. THE CENTERLINE OF ALL FRAMES IS THE JOINT LINE OF BOTTOM AND SIDE FRAME MEMBERS. REFER TO SIDE VIEW DRAWING

# BREADTH AND SIDE VIEW

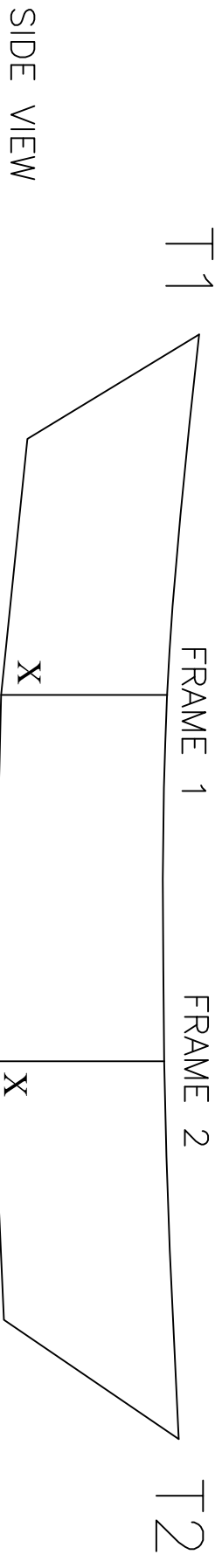
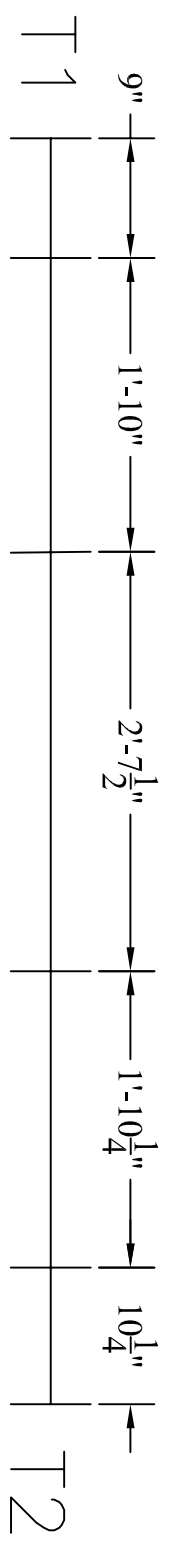

CENTER LINE OF FRAMES IS THE LINE THAT FOLLOWS THE UNION OF BOTTOM AND SIDE FRAME MEMBERS. "X" REPRESENTS THE SIDE BOTTOM FRAME MEMBER IS ON

TABLE OF HEIGHTS FROM BASELINE

|       |       |        |        |       |
|-------|-------|--------|--------|-------|
|       | T1    | FRAME1 | FRAME2 | T2    |
| CHINE | 0-3-1 | 0-0-7  | 0-0-0  | 0-1-1 |
| SHEER | 1-5-7 | 1-3-1  | 1-2-7  | 1-4-1 |

# INTERIOR APPOINTMENTS

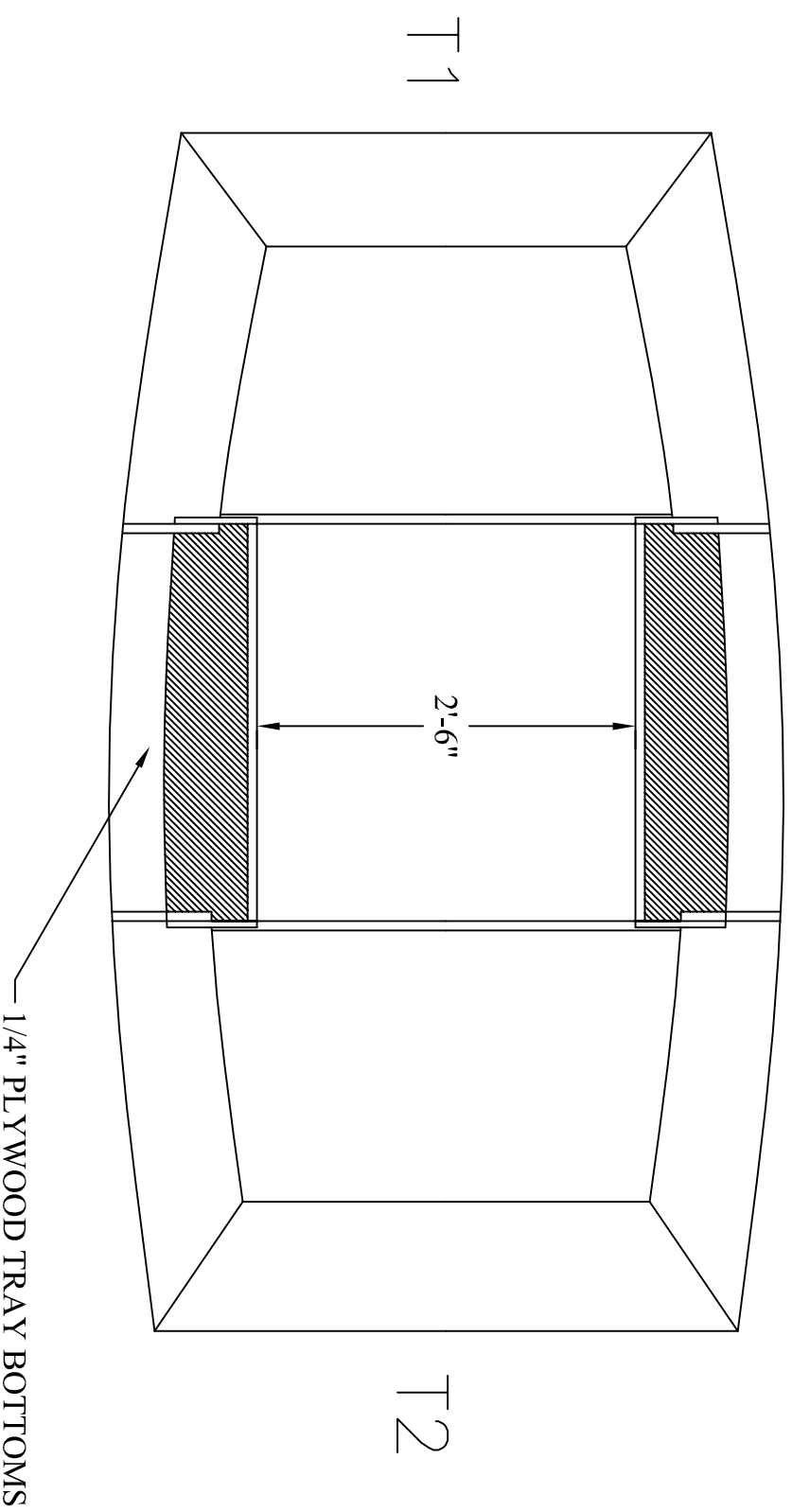

RAIL SUPPORT BRACKETS FOR FRAME #1

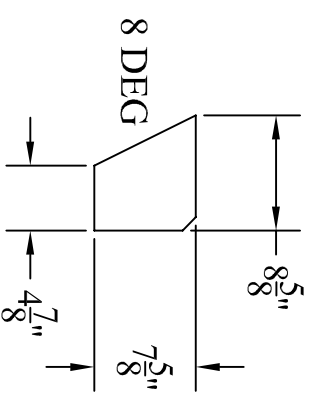

RAIL SUPPORT BRACKETS FOR FRAME #2

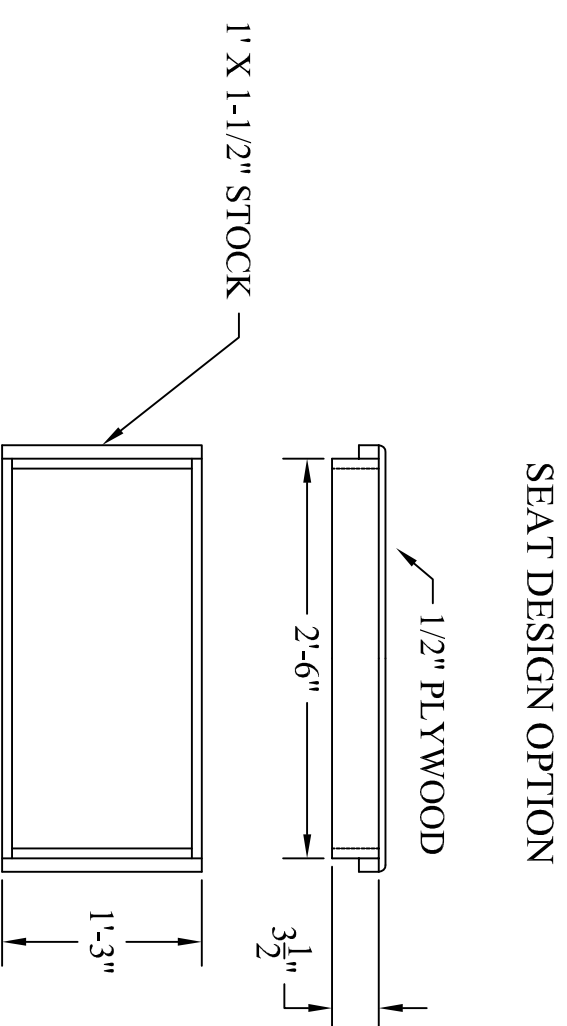
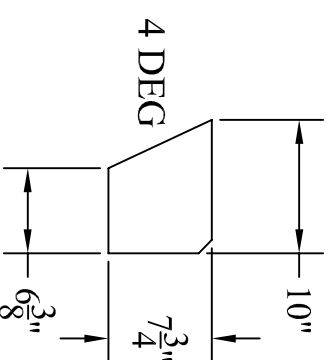

## OAR BLOCKS



\*USE 1-1/2" X 3.5" X 10" WHITE OAK, DELRIN OR HARDWOOD

\* MOUNT CENTERED BETWEEN FRAMES

# BILL OF MATERIALS

| MATERIAL  | DESCRIPTION                     | QTY   |
|---|---------------------------------|-------|
| 1/4" MARINE PLYWOOD-4'X8' SHEET. MERANTI, AB MARINE FIR OR EQUIVALENT | HULL SIDES                      | 1     |
| 3/8" MARINE PLYWOOD-4'X8' SHEET. MERANTI, AB MARINE FIR OR EQUIVALENT | HULL BOTTOM, TRANSOMS, SEATS    | 2     |
| 2" X 4" X10" WHITE OAK, ASH OR DOUGLAS FIR                            | ORLOCK BLOCKS                   | 2     |
| 1 x 4 LUMBER, DOUGLAS FIR, WESTERN RED CEDAR OR EQUIVALENT            | FRAMES AND TRANSOM SIDE MEMBERS | 30 FT |
| 5/8" x 2" x 9' WHITE OAK, ASH OR DOUGLAS FIR                          | CHINES AND TRIM                 | 8     |
| RING NAILS #14 x 1-1/4"   | HULL TO FRAMES                  | 1 LB  |
| WOOD SCREW, #8 x 1-1/4"   | FRAMES, OUTER CHINE CAP         | 100   |
| WOOD SCREW, #8 x 3/4"   | INNER CHINE                     | 100   |
| CARRIAGE BOLTS, 1/4" x 4-1/2"   | INNER RAIL                      | 16    |
| STEEL WASHERS, 1/4"   | INNER RAIL                      | 16    |
| ACORN NUTS, 1/4"  | INNER RAIL                      | 16    |
|   |                                 |       |

\*PLANS ARE FOR THE HULL ONLY. BE ADVISED THAT INTERIOR APPOINTMENTS, SEAT AND ACCESSORIES WILL REQUIRE ADDITIONAL MATERIALS AND COSTS. REFER TO ADDITIONAL DOCUMENTATION FOR SUPPLEMENTAL MATERIALS.